

TS EN1092-1

Kaynak Boyunlu Flanş (Tip 11)

PN40

EBAT		FLANŞ ÖLÇÜLERİ				BOYUN ÖLÇÜLERİ				CONTA ÇİZGİSİ YÜZEYİ		DELİK ÖZELLİKLERİ				BİRİM AĞIRLIK
DN	A	B ₂	D	C ₁	H ₂	N ₁	s	R	H ₃	d ₁	f ₁	K	n	Cıvata	L	(kg/adet)
10	17	13	90	16	35	28	2	4	6	40	2	60	4	M12	14	0,67
15	21	17	95	16	38	32	2	4	6	45	2	65	4	M12	14	0,76
20	27	22	105	18	40	40	2	4	6	58	2	75	4	M12	14	1,08
25	34	29	115	18	40	46	3	4	6	68	2	85	4	M12	14	1,30
32	42	37	140	18	42	56	3	6	6	78	2	100	4	M16	18	1,88
40	48	43	150	18	45	64	3	6	7	88	3	110	4	M16	18	2,11
50	60	55	165	20	48	75	3	6	8	102	3	125	4	M16	18	2,82
65	76	70	185	22	52	90	3	6	10	122	3	145	8	M16	18	3,67
80	89	83	200	24	58	105	3	8	12	138	3	160	8	M16	18	4,73
100	114	107	235	24	65	134	4	8	12	162	3	190	8	M20	22	6,43
125	140	132	270	26	68	162	4	8	12	188	3	220	8	M24	26	8,85
150	168	159	300	28	75	192	5	10	12	218	3	250	8	M24	26	11,60
200	219	207	375	34	88	244	6	10	16	285	3	320	12	M27	30	21,00
250	273	259	450	38	105	306	7	12	18	345	3	385	12	M30	33	34,30
300	324	308	515	42	115	362	8	12	18	410	4	450	16	M30	33	47,90
350	356	338	580	46	125	408	9	12	20	465	4	510	16	M33	36	70,00
400	406	384	660	50	135	462	11	12	20	535	4	585	16	M36	39	99,50
450	457	432	685	57	135	500	13	12	20	560	4	610	20	M36	39	106,00
500	508	480	755	57	140	562	14	12	20	615	4	670	20	M39	42	132,00
600	610	578	890	72	150	666	16	12	20	735	5	795	20	M45	48	212,00

*Tüm ölçüler mm olarak verilmektedir. Tabloda yer almayan ölçüleri için bizimle iletişime geçiniz.



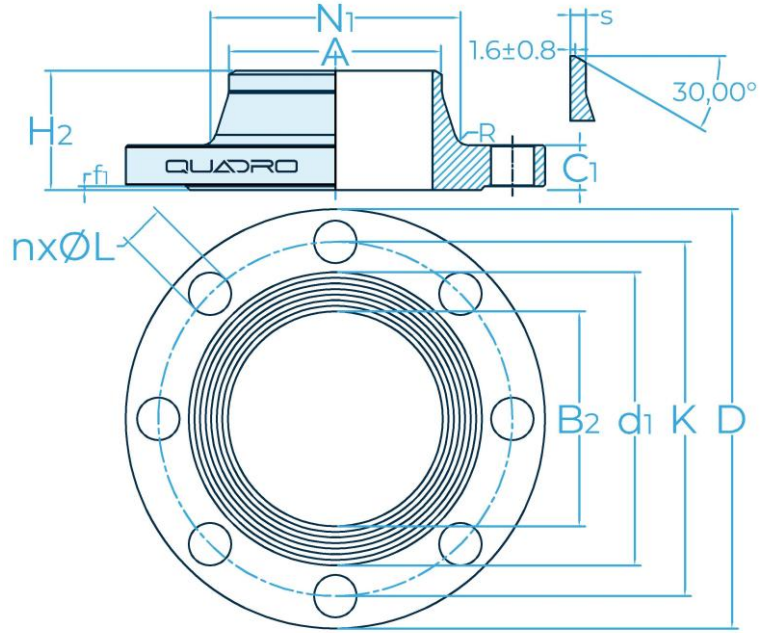

DIN2635

Kaynak Boyunlu Flanş (Tip 11)

PN40

EBAT		FLANŞ ÖLÇÜLERİ				BOYUN ÖLÇÜLERİ				CONTA ÇİZGİSİ YÜZEYİ		DELİK ÖZELLİKLERİ				BİRİM AĞIRLIK
DN	A	B ₂	D	C ₁	H ₂	N ₁	s	R	H ₃	d ₁	f ₁	K	n	Cıvata	L	(kg/adet)
10	17	14	90	16	35	28	2	4	6	40	2	60	4	M12	14	0,67
15	21	17	95	16	38	32	2	4	6	45	2	65	4	M12	14	0,76
20	27	22	105	18	40	40	2	4	6	58	2	75	4	M12	14	1,08
25	34	29	115	18	40	46	3	4	6	68	2	85	4	M12	14	1,30
32	42	37	140	18	42	56	3	6	6	78	2	100	4	M16	18	1,88
40	48	43	150	18	45	64	3	6	7	88	3	110	4	M16	18	2,11
50	60	55	165	20	48	75	3	6	8	102	3	125	4	M16	18	2,82
65	76	70	185	22	52	90	3	6	10	122	3	145	8	M16	18	3,67
80	89	83	200	24	58	105	3	8	12	138	3	160	8	M16	18	4,73
100	114	107	235	24	65	134	4	8	12	162	3	190	8	M20	22	6,43
125	140	132	270	26	68	162	4	8	12	188	3	220	8	M24	27	8,78
150	168	159	300	28	75	192	5	10	12	218	3	250	8	M24	27	11,50
175	194	183	350	32	82	218	6	10	15	260	3	295	12	M27	30	17,40
200	219	207	375	34	88	244	6	10	16	285	3	320	12	M27	30	21,00
250	273	259	450	38	105	306	7	12	18	345	3	385	12	M30	33	34,30
300	324	308	515	42	115	362	8	12	18	410	4	450	16	M30	33	47,90
350	356	338	580	46	125	408	9	12	20	465	4	510	16	M33	36	70,00
400	406	384	660	50	135	462	11	12	20	535	4	585	16	M36	39	99,50
450	457	432	685	50	135	500	13	12	20	560	4	610	20	M36	39	96,80
500	508	480	755	52	140	562	14	12	20	615	4	670	20	M39	42	124,00

*Tüm ölçüler mm olarak verilmektedir. Tabloda yer almayan ölçüleri için bizimle iletişime geçiniz.

